



+38 (050) 4-999-555

+38 (057) 714-09-09

www.irbis.ua



MODUTECH®

IRBIS є ексклюзивним дистриб'ютором в Україні

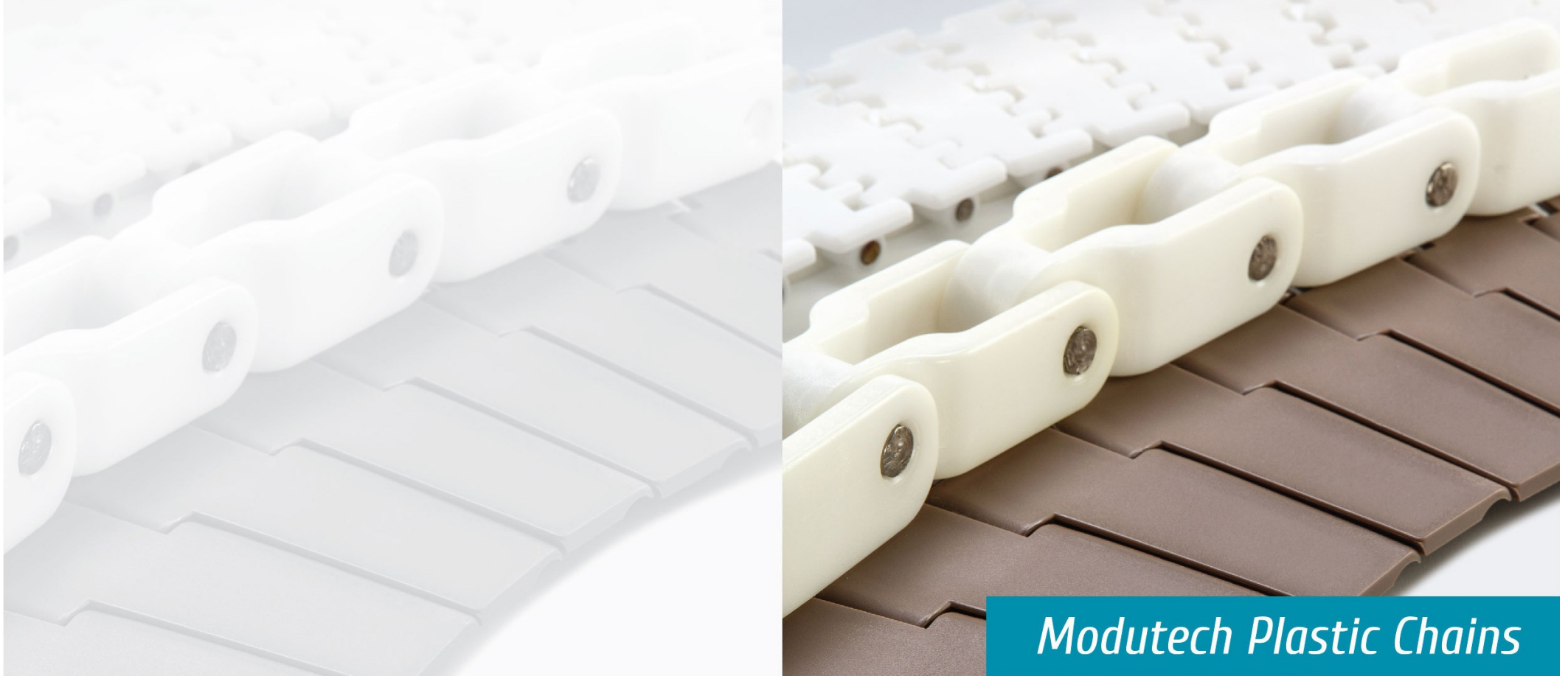

Modutech Plastic Chains

Chain Brochure



İZMİR Head Quarter

Ankara Asfaltı 25.km Kızılcıklar Mevkii Kuyucak Kemalpaşa / Izmir - TURKEY

Tel : +90 232 877 00 22 (pbx) Fax: +90 232 877 01 11

e-mail: info@modutech.com.tr

www.modutech.com.tr

www.modutech.com.tr

MD 820 Chain Series

Straight Running-Single Hinge Chains

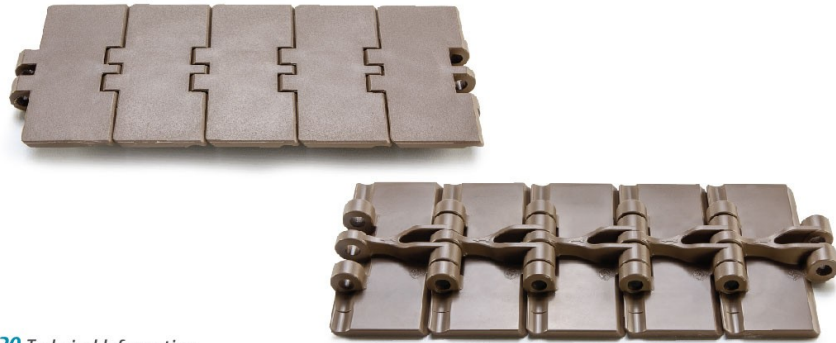

MD 820 Technical Information

MD 820 SERIES STRAIGHT RUNNING - SINGLE HINGE CHAINS						
PRODUCT CODE	WIDTH (W)		PLATE THICKNESS (S)	TENSILE STRENGTH		WEIGHT
	mm	inch		Kg/m	N/m	
MD 820-K325-LF	82,5	3,25	4	140	1400	0,84
MD 820-K400-LF	101,6	4,00	4	140	1400	0,95
MD 820-K450-LF	114,3	4,50	4	140	1400	1,05
MD 820-K600-LF	152,4	6,00	4,8	140	1400	1,30
MD 820-K750-LF	190,5	7,50	4,8	140	1400	1,55

* Self-lubricating low friction acetal resin, brown-coloured.

* Pins in special chrome-nickel 304 stainless steel

* Standard packing lengths = 80 pitches = 3,048 m

MD 820 Technical Drawings

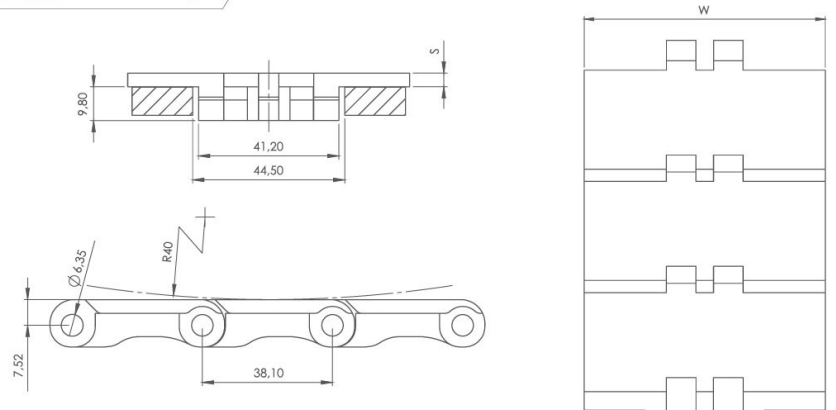

www.modutech.com.tr

MD 821 Chain Series

Straight Running-Double Hinge Chains



MD 821 Technical Information

MD 821 SERIES STRAIGHT RUNNING - DOUBLE HINGE CHAINS						
PRODUCT CODE	WIDTH (W)		PLATE THICKNESS (S)	TENSILE STRENGTH		WEIGHT
	mm	inch		Kg/m	N/m	
MD 821-K750-LF	190,5	7,50	4,8	270	2700	2,70
MD 821-K1000-LF	254,0	10,00	4,8	270	2700	3,10
MD 821-K1200-LF	304,8	12,00	4,8	270	2700	3,40

* Self-lubricating low friction acetal resin, brown-coloured.

* Pins in special chrome-nickel 304 stainless steel

* Standard packing lengths = 80 pitches = 3,048 m

MD 821 Technical Drawings

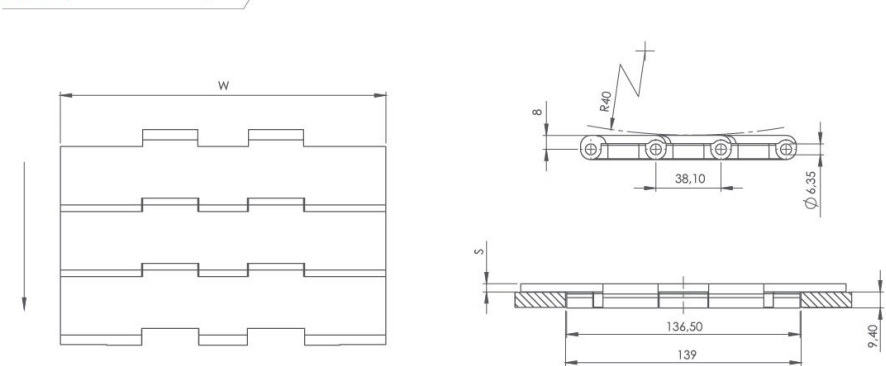

www.modutech.com.tr

MD 880-879 Chain Series

Standart Radius Sideflexing Chains



MD 880-879 Technical Information

MD 880-879 SERIES STANDARD RADIUS SIDEFLEXING CHAINS							
PRODUCT CODE	WIDTH (W)		PLATE THICKNESS (S)	RADIUS (R)	TENSILE STRENGTH		WEIGHT
	mm	inch			Kg/m	N/m	
MD 880-K325-LF	82,5	3,25	4	400	200	2000	0,90
MD 880-K400-LF	101,6	4,00	4	400	200	2000	1,00
MD 880-K450-LF	114,3	4,50	4	400	200	2000	1,10
MD 879-K600-LF	152,4	6,00	4,8	400	220	2200	1,30
MD 879-K750-LF	190,5	7,50	4,8	400	220	2200	1,50

- * Self-lubricating low friction acetal resin, brown-coloured.
- * Pins in special chrome-nickel 304 stainless steel
- * Standard packing lengths = 80 pitches = 3,048 m

MD 880-879 Technical Drawings

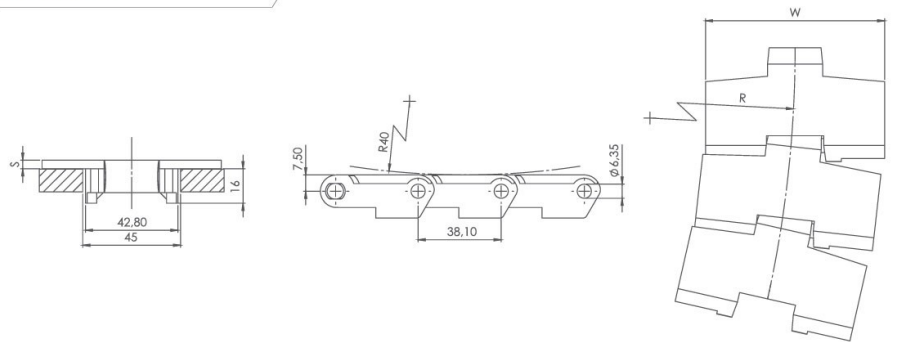

www.modutech.com.tr

MD 880-879 TAB Chain Series

Standart Radius Sideflexing Chains



MD 880-879 TAB Technical Information

MD 880-879 TAB SERIES STANDARD RADIUS SIDEFLEXING CHAINS							
PRODUCT CODE	WIDTH (W)		PLATE THICKNESS (S)	RADIUS (R)	TENSILE STRENGTH		WEIGHT
	mm	inch			Kg/m	N/m	
MD 880 TAB-K325-LF	82,5	3,25	4	400	200	2000	0,95
MD 880 TAB-K400-LF	101,6	4,00	4	400	200	2000	1,05
MD 880 TAB-K450-LF	114,3	4,50	4	400	200	2000	1,15
MD 879 TAB-K600-LF	152,4	6,00	4,8	400	220	2200	1,35
MD 879 TAB-K750-LF	190,5	7,50	4,8	400	220	2200	1,55

- * Self-lubricating low friction acetal resin, brown-coloured.
- * Pins in special chrome-nickel 304 stainless steel
- * Standard packing lengths = 80 pitches = 3,048 m

MD 880-879 TAB Technical Drawings

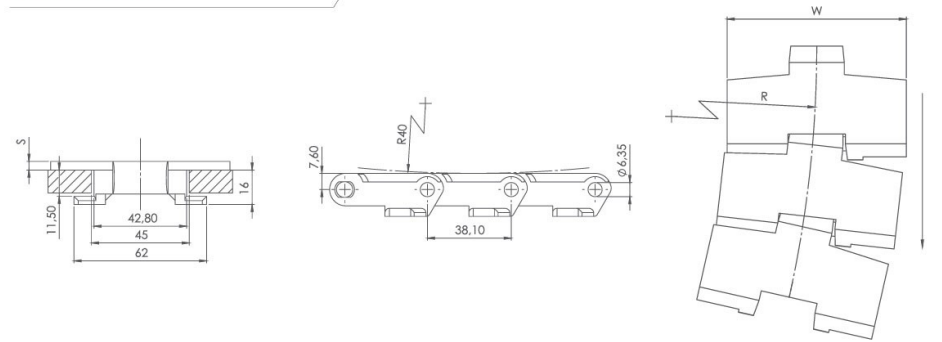

www.modutech.com.tr

Wide range of high quality
Modutech chains for the most
challenging applications.



MD 1701 R / MD 1701 TAB R Chain Series

Multiflex Chains



MD 1701 R / MD 1701 TAB R Technical Information

MULTIFLEX CHAINS						
PRODUCT CODE	PITCH	WIDTH (W)		RADIUS (R)	TENSILE STRENGTH	WEIGHT
		mm	inch			
MD 1701 R	50	52,5	2,05	150	255	1,58
MD 1701 TAB R	50	52,5	2,05	150	255	1,65

- * Self-lubricating low friction acetal resin, white-coloured.
- * Pins in special chrome-nickel 304 stainless steel
- * Standard packing lengths = 122 pitches = 6,10 m

MD 1701 TAB R Technical Drawings

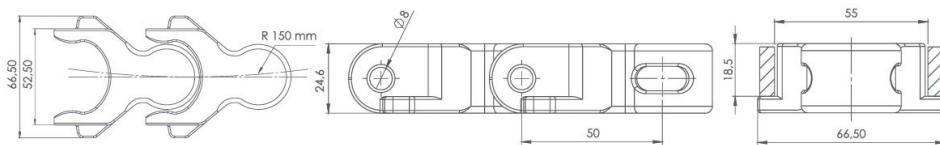

MD 1701 R Technical Drawings

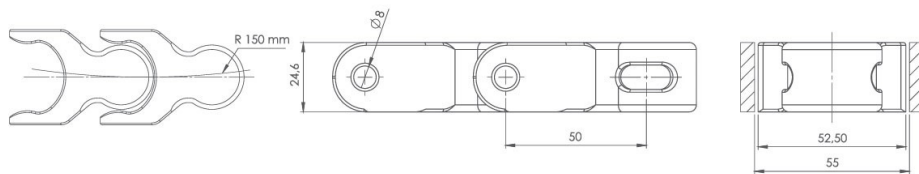

www.modutech.com.tr

MD 600 S / MD 600 TAB S Chain Series

Plastic Case Conveyor Chains



MD 600 S / MD 600 TAB S Technical Information

PLASTIC CASE CONVEYOR CHAINS					
PRODUCT CODE	PITCH	WIDTH (W)		TENSILE STRENGTH	WEIGHT
		mm	inch		
MD 600 S	63,5	43	1,70	400	1,55
MD 600 TAB S	63,5	43	1,70	400	1,65

- * Self-lubricating low friction acetal resin, white-coloured.
- * Pins in special chrome-nickel 304 stainless steel
- * Standard packing lengths = 96 pitches = 6,096 m

MD 600 S Technical Drawings

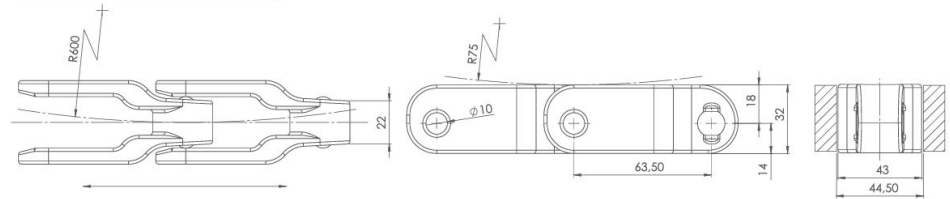

MD 600 TAB S Technical Drawings

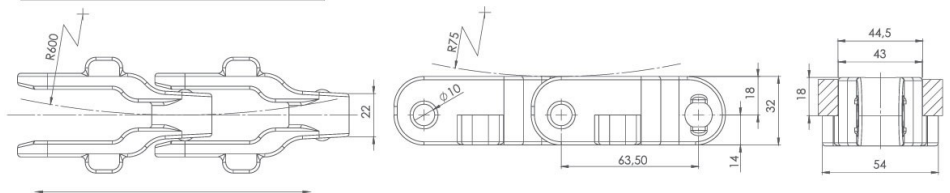

www.modutech.com.tr

Flexi Chain Series



Flexi Chain Series Technical Information

FLEXI CHAIN SERIES							
PRODUCT CODE	WIDTH (W)		PLATE THICKNESS	SIDEFLEX RADIUS (RS)	TENSILE STRENGTH		WEIGHT
	mm	inch			Kg/m	N/m	
FLEXI-K325 -LF	82,5	3,25	4	140	110	1100	1,25
FLEXI-K450 -LF	114,3	4,50	4	160	110	1100	1,55

* Self-lubricating low friction acetal resin, white-coloured.

* Pins in special chrome-nickel 304 stainless steel

* Standard packing lengths = 91 pitches = 3,048 m

Flexi Chain Series Technical Drawings

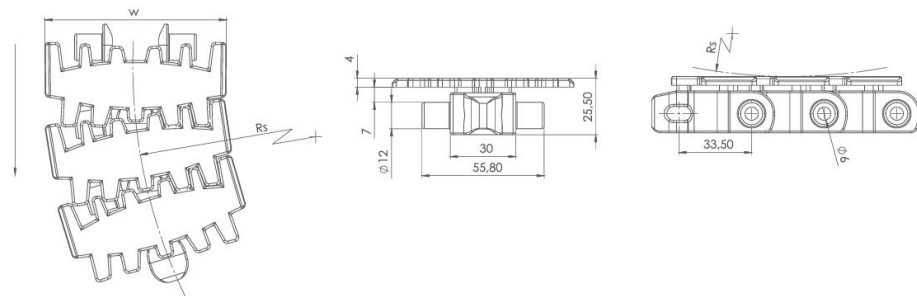

www.modutech.com.tr

Sprockets



MD 820 Sprockets Technical Drawings

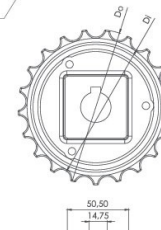

Classic Sprocket Series MD820					
Product Code	Number of Teeth	Do (mm)	Di (mm)	Round Bore (Ø)	Square Bore
MD 820	21	128	114	25	30
MD 820	25	152	138	25	30

* Special sprockets and hub size are being manufactured on your request.

MD 1701 R Sprockets Technical Drawings

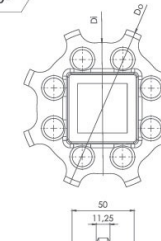

Classic Sprockets Series MD1701					
Product Code	Number of Teeth	Do (mm)	Di (mm)	Round Bore (Ø)	Square Bore
MD 1701 R	8	132	107	25	40 x 40
MD 1701 R	10	166	107	25	40 x 40

* Special sprockets and hub size are being manufactured on your request.

MD 600 S Sprockets Technical Drawings

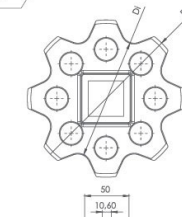

Classic Sprockets Series MD600					
Product Code	Number of Teeth	Do (mm)	Di (mm)	Round Bore (Ø)	Square Bore
MD 600	8	177	138	25	40 x 40
MD 600	10	221	176	25	40 x 40

* Special sprockets and hub size are being manufactured on your request.

MD 880 Sprockets Technical Drawings

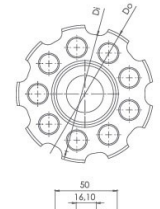

Classic Sprocket Series MD880					
Product Code	Number of Teeth	Do (mm)	Di (mm)	Round Bore (Ø)	Square Bore
MD 880	9	111	97	25	30
MD 880	11	135	121	25	30

* Special sprockets and hub size are being manufactured on your request.

Flexi Chains Sprocket Technical Drawings

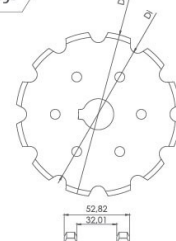

Classic Sprockets Series Flexi Chains					
Product Code	Number of Teeth	Do (mm)	Di (mm)	Round Bore (Ø)	Square Bore
FLEXI CHAIN	12	133	115	25	40 x 40

* Special sprockets and hub size are being manufactured on your request.

www.modutech.com.tr